

**The Outlaw
Bookshelf Loudspeakers
BLS-B(C) Black (and Cherry)**



Outlaw Owner's Manual

Table of Contents

3	The Outlaw Bookshelf Loudspeakers BLS-B(C)
3	Unpacking
3	Contents
3	Loudspeaker Controls and Connections
3	Setup Guide
3	Connecting To Your System
3	Preparing the Speaker Wire for Installation
3	Loudspeaker Rear Panel
4	Option 1: Connecting to a system with single speaker wire.
4	Option 2: Connecting to a system in a bi-wire scheme.
5	Option 3: Connecting to a system in a bi-amplify scheme.
6	Notes On Speaker Placement
6	Setting the Outlaw Loudspeaker's Controls
6	Boundary Compensation Switch
6	High Frequency Switch
6	External System Adjustments
6	Crossovers for use with powered subwoofers
7	Volume Level
7	Surround Sound Considerations
7	Caring for your Speakers
7	Troubleshooting Guide
7	Specifications
8	The Outlaw Audio 30-Day Satisfaction Guarantee
8	Outlaw Audio Limited Warranty

The contents of this manual are Copyright © 2007 by Outlaw Audio, LLC, and may not be duplicated or reproduced by any means, whether physical, electronic or otherwise without prior written consent from Outlaw Audio.

Outlaw Audio and the Outlaw Audio logo are registered trademarks of Outlaw Audio, LLC.

Any trademark not acknowledged is recognized as the property of the respective owner.

Specifications are those in effect at the time of printing. Outlaw Audio reserves the right to change specifications or designs at any time without notice or liability to modify or upgrade units previously sold.

For Future Reference

Record your Bookshelf Loudspeaker serial number and date of purchase here. It is found on the back panel.

Model Number _____

Serial Number _____

Date of Purchase _____

The Outlaw Bookshelf Loudspeakers BLS-B(C) Black (and Cherry)

Congratulations on your purchase of Outlaw Audio Loudspeakers. You now own a pair of one of the finest bookshelf speakers available. **The Outlaw Bookshelf Loudspeakers** provide remarkable performance in their price range. True to even the most demanding source material, your new Outlaw Loudspeakers won't skip a beat.

After a brief "break-in" period, you'll discover a sound that maintains its image regardless of where you are in the room, a low frequency response that is both deep and controlled that belies its compact size, and a natural timbre that sustains the important midrange integrity of the very best recordings.

This is all accomplished through precision engineering and meticulous manufacturing standards here in the United States. From our custom designed tweeter built with precision Scandinavian parts to 100% film capacitors, the Outlaw Bookshelf Loudspeaker's design and assembly takes nothing for granted. In the manufacturing process every Outlaw Loudspeaker is measured and calibrated to match our reference design plus or minus 0.5 dB. That means your pair of speakers will be virtually identical, a standard that is only found in the world's finest loudspeakers.

The many features of the Outlaw Bookshelf Loudspeakers include:

- A custom designed 25mm soft dome tweeter with copper cap, vented former, ferro fluid cooling and a full video shield and bucking magnet to virtually eliminate any stray magnetic forces
- A long throw 5-1/4" SEAS woofer, for deep controlled bass extension
- Identically sized (internal and external) port baffle areas to equalize internal and external air pressures, and to provide fully symmetrical woofer excursion
- Internal and external matching port flares to provide virtually inaudible air turbulence
- Furniture grade cabinetry including book-matched veneers for cherry finish and high-quality, hand-painted black finish on MDF
- True Bi-amp/Bi-wire design using precision five-way binding posts with separate crossovers for woofer and tweeter
- A proprietary 3-position Boundary Compensation switch for wall and corner placement
- A proprietary 3-position High Frequency switch to compensate for either heavily dampened or live rooms

We encourage you to carefully follow the setup information provided in the following pages to ensure you get every last note of audiophile performance from your new speakers.

Unpacking

The carton and packing materials used in shipping your new speakers were specially designed to cushion them from the shocks and vibrations of shipping. We strongly suggest that you save the carton and packing materials to use if you move, or if the speakers ever need to be shipped back to us for any reason.

To minimize the size of the carton in storage, you may wish to flatten it by carefully opening the top and bottom flaps and folding the carton flat. Packing materials that cannot be collapsed should be saved along with the carton in a plastic bag.

Contents

After unpacking your new speakers, please confirm that the following items have been included.

- 2 BLS-B(C) Black (or Cherry) Loudspeakers
- 2 Black Metal Grills (pre-installed)
- Owner's Manual

If any of the above is missing from your shipment, please contact Outlaw Audio immediately at 866-OUTLAWS.

Loudspeaker Controls and Connections

A Boundary Switch

This three-position switch provides a (0dB, 2dB and 4dB) reduction in upper bass frequencies to maintain a linear response for wall or corner loaded speaker placements.

B High Frequency Speaker Binding Posts

Use these or the low frequency terminals to connect the speaker to the amplifier.

C Low Frequency Speaker Binding Posts

Use these or the high frequency terminals to connect the speaker to the amplifier.

D High Frequency Switch

This three-position switch provides a (-2dB, 0dB, +2dB) treble compensation for bright or heavily dampened listening environments.

E Binding Post Jumpers

These connect the two pairs of binding posts and should remain installed unless using a bi-wire or bi-amplify connection scheme.

Setup Guide

Connecting To Your System

To get the maximum performance from your new Outlaw Loudspeaker system it must be properly connected, positioned properly within the room and configured to match your listening environment. There are three primary connection styles compatible with your Outlaw Loudspeakers. These include the standard one wire (per) speaker connection, bi-wiring which uses either a pair of speaker wires or a custom bi-wire cable and a single amplifier channel per speaker, or bi-amplifying which uses two speaker wires and two power amplifiers per speaker.

Loudspeaker Rear Panel

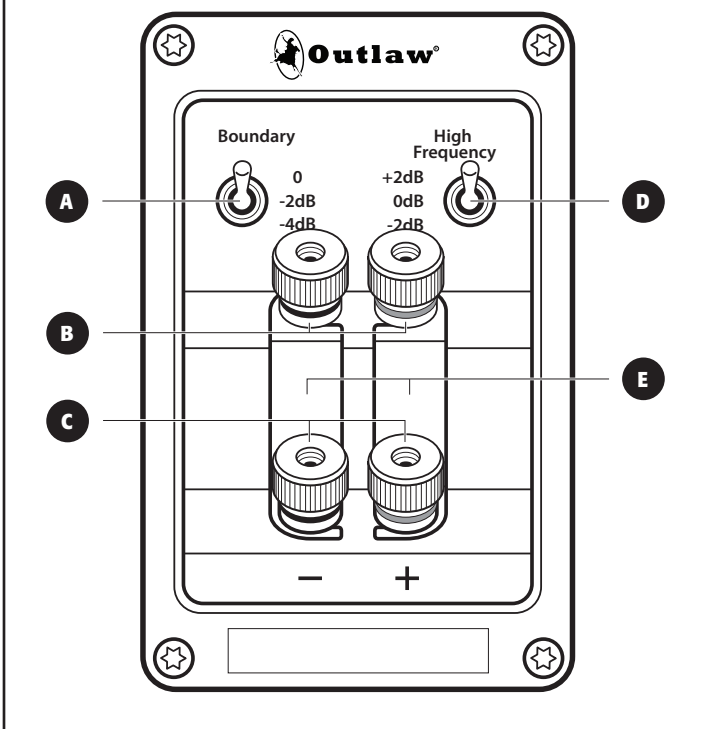

Preparing the Speaker Wire for Installation

High quality speaker wires are essential for optimal performance. We recommend the use of a heavy gauge (16 or heavier) oxygen-free multi-strand copper wire. For lengths over 25 feet, a heavier gauge of wire should be used. As with other gauge based conductors, the lower the number the heavier the gauge.

When purchasing wire, look for cabling that clearly marks polarity on one conductor. Often speaker wire manufacturers will use a single solid line or their logo on one side for this purpose. This will make connections easier later on. Most installers consider the marked conductor their "positive" lead.

Since your Outlaw Bookshelf Loudspeakers offer true five-way binding posts you can use speaker wires that have terminated ends such as banana plugs, spades, or pins. When using spades, they must be compatible with 5/16 inch posts.

To prepare your non-terminated wire for installation, you will need to perform the following tasks:

1. Split each end of the speaker wire in half leaving approximately two inches of "separate conductors" as shown below.
2. Remove a half inch of insulation from each conductor, also shown below.
3. Separately twist each stranded wire together ensuring that all four leads are kept apart.

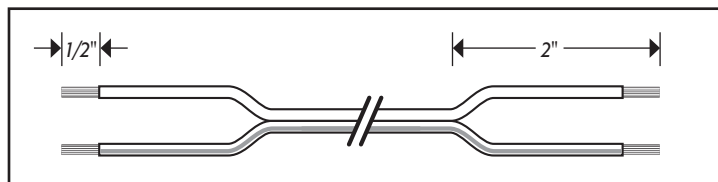

Option 1: Connecting to a system with single speaker wire.

This is the most common way to connect an individual speaker to a power amplifier or receiver. A standard 16 or 14 gauge speaker wire is used to join the amp and speaker together.

CAUTION: To prevent damage to your amplifier or speakers and avoid the risk of electrical shock always disconnect the power to your receiver or amplifier when making any system connections.

To connect each speaker with a single speaker wire, carefully follow the steps below:

1. Turn off all system components and unplug the receiver or amplifier.
2. Loosen one set of the Outlaw Loudspeaker's binding posts.

NOTE: Be sure that the binding posts jumpers remain installed.

3. Insert the appropriate polarity wire through the postholes on the binding post.
4. Carefully tighten the binding post until snug. Over tightening will strip the binding post and prevent a solid connection.
5. Repeat steps 2-4 at the amplifier binding post with the opposite end of the speaker wire.

NOTE: Remember that polarity must be maintained between speaker and amplifier, ie. positive terminal (red post) on speaker to positive terminal on power amplifier.

CAUTION: Check terminal posts on both connections (speaker and amplifier) to ensure that loose copper strands have not been allowed to "short" the binding post pairs. Any loose strands that touch both the positive and negative terminal posts must be removed before powering up the amplifier. Failure to do so may result in damage to the amplifier or speaker.

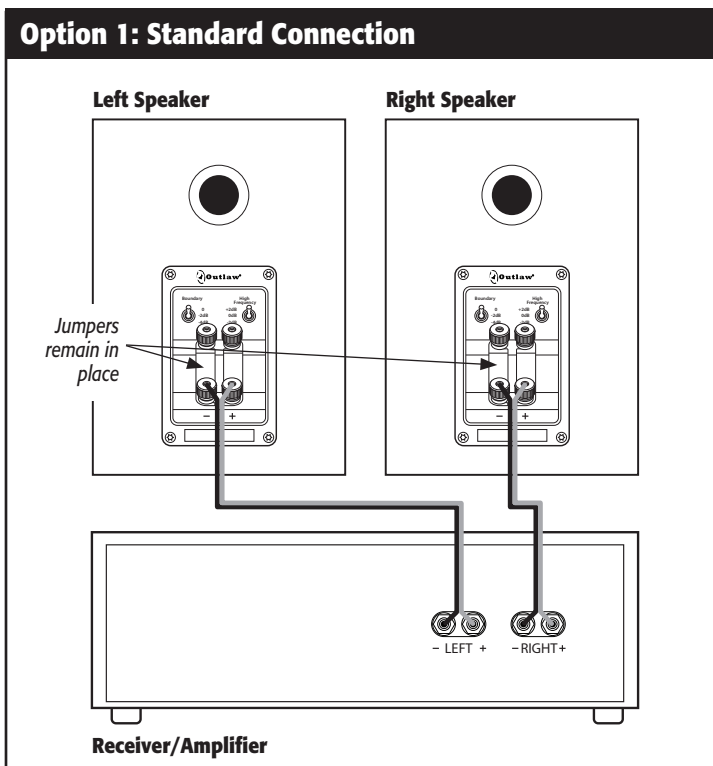

Option 2: Connecting to a system in a bi-wire scheme.

Some audiophiles prefer to use a bi-wire scheme when connecting their speakers and amplifiers. While this connection type does not provide the added power of a bi-amplified wiring scheme (described in the next section), it can be beneficial in reducing the amount of EMF (electromotive force) that the woofer generates on the more "voltage-sensitive" high frequency circuitry.

To connect your speakers using the bi-wiring option, carefully follow the steps below:

1. Turn off all system components and unplug the receiver or amplifier.
2. Connect both pairs of speaker wire on one end by twisting the positive (marked) copper ends together as shown at right.
3. Repeat step 2 for the negative (unmarked) copper leads on the same end of the speaker wire, also shown at right.

NOTE: Some speaker wire manufacturers offer a speaker wire specifically designed for bi-wire applications. With these wires, Steps 2 and 3 are unnecessary.

4. Loosen your receiver or amplifier's corresponding binding posts.
5. Insert the appropriate polarity wire through the postholes on the amplifier's binding post.

Be sure to use the "double speaker wire" connection you have just created. The opposite end of this wire will have four leads, a pair for each set of speaker binding posts.

6. Carefully tighten the binding post until snug. Over tightening will strip the binding post and prevent a solid connection.
7. Loosen both sets of the Outlaw Bookshelf Loudspeaker's binding posts.
8. Remove both binding posts jumpers.

CAUTION: Failure to remove these jumpers using this connection scheme will result in damage to your power amplifier and/or speakers.

9. Select one speaker wire lead to connect to the high frequency binding posts.
10. Insert the appropriate polarity wire through the postholes on the binding post.
11. Carefully tighten the binding post until snug. Over tightening will strip the binding post and prevent a solid connection.
12. Repeat steps 9-11 for the low frequency binding posts.

NOTE: Remember that polarity must be maintained between speaker and amplifier, ie. positive terminal (red post) on speaker to positive terminal on power amplifier.

CAUTION: Check terminal posts on both connections (speaker and amplifier) to ensure that loose copper strands have not been allowed to "short" the binding post pairs. Any loose strands that touch both the positive and negative terminal posts must be removed before powering up the amplifier. Failure to do so may result in damage to the amplifier or speaker.

Option 3: Connecting to a system in a bi-amplify scheme.

Like the bi-wire scheme described above, a bi-amplified wiring scheme does reduce the amount of EMF on the speaker's high frequency circuitry. However, in a bi-amplified wiring scheme, the user provides separate amplification for both sections (high frequencies and low frequencies) of the speaker.

Some audiophiles tend to prefer this method of connectivity as it ensures that the more "power hungry" woofers are not limited by the additional power demands of the high frequency portion of the speaker while still maintaining the EMF benefits of a bi-wire scheme.

NOTE: In a bi-amplify scheme, it is necessary to use matching amplifiers for both high frequency and low frequency connections, otherwise an imbalance will occur between each portion of the speaker. This imbalance will negatively impact performance. Also, using the "A +B" terminals on a receiver does not offer an improved connection over using a single speaker wire from the "A" terminals. Separate amplifier channels are required to receive the benefits of bi-amplification.

1. Turn off all system components and unplug the receiver/pre-amp and amplifiers.
2. Connect a Y-adapter to the corresponding pre-amp output on your processor.
3. Connect the two amplifier channels you intend to use, one to each of the two outputs the Y-adapter has created.
4. Loosen the corresponding binding posts on the power amplifier you plan to use for the high frequency portion of your Outlaw Bookshelf Loudspeakers.
5. Insert the appropriate polarity wire through the postholes on the amplifier's binding post.
6. Carefully tighten the binding post until snug. Over tightening will strip the binding post and prevent a solid connection.
7. Repeat steps 3-6 for the power amplifier you intend to use to drive the low frequency portion of your Outlaw Bookshelf Loudspeakers.
8. Loosen both sets of the Outlaw Loudspeaker's binding posts.
9. Remove both binding post jumpers.

CAUTION: Failure to remove these jumpers using this connection scheme will result in damage to your power amplifier and or speakers.

10. Connect your "high frequency" amplifier to the high frequency binding posts on your Outlaw Loudspeaker by inserting the appropriate polarity wires through the postholes on the binding post.
11. Carefully tighten the binding posts until snug. Over tightening will strip the binding post and prevent a solid connection.
12. Repeat steps 10-11 for the low frequency portion of your Outlaw Loudspeakers.

NOTE: Remember that polarity must be maintained between speaker and amplifier, i.e. positive terminal (red post) on speaker to positive terminal on power amplifier.

CAUTION: Check terminal posts on both connections (speaker and amplifier) to ensure that loose copper strands have not been allowed to "short" the binding post pairs. Any loose strands that touch both the positive and negative terminal posts must be removed before powering up the amplifier. Failure to do so may result in damage to the amplifier or speaker.

Option 2: Bi-Wired Connection

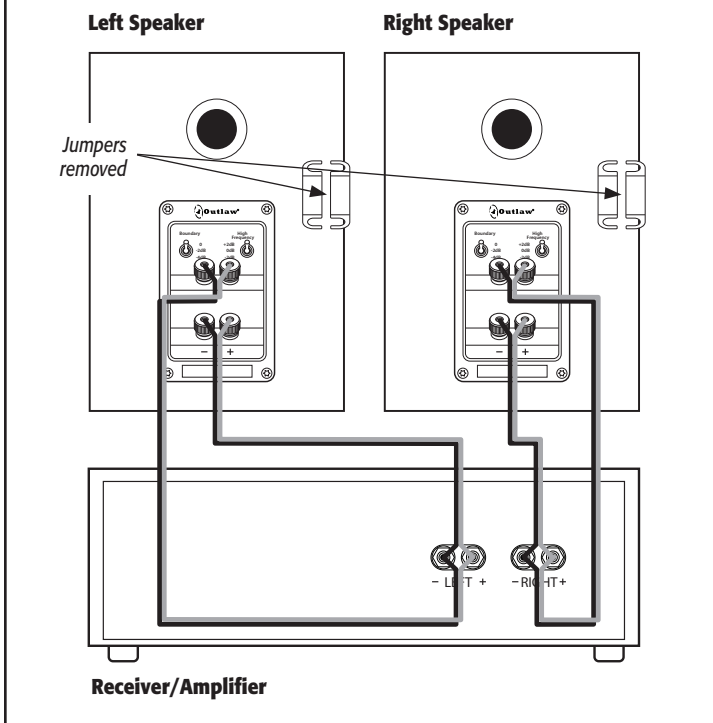

Option 3: Bi-Amplified Connection

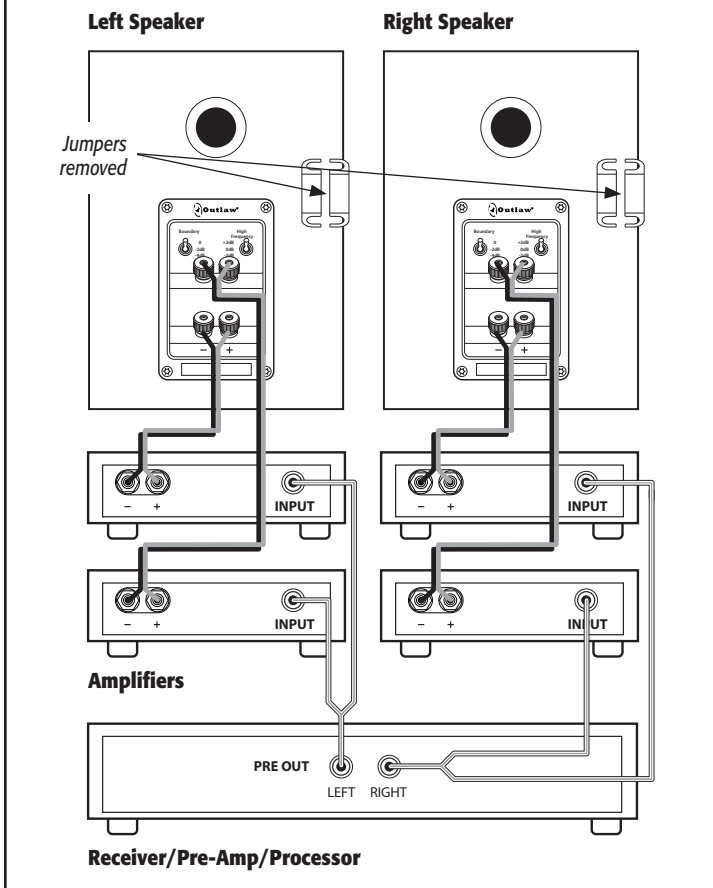

Notes on Speaker Placement

The following suggestions should be adhered to as closely as possible. While each listening room imparts its own sonic compromises, these guidelines will help you achieve the greatest performance from your Outlaw Loudspeaker system.

- Placing your speakers at equal distances from the listening position, thus creating an “equilateral” triangle will help create an optimal stereo imaging environment. See diagram.
- Soundstage is directly affected by “toe-in”. Pointing the loudspeakers directly at the sweet spot creates the most accurate soundstage. See diagram.

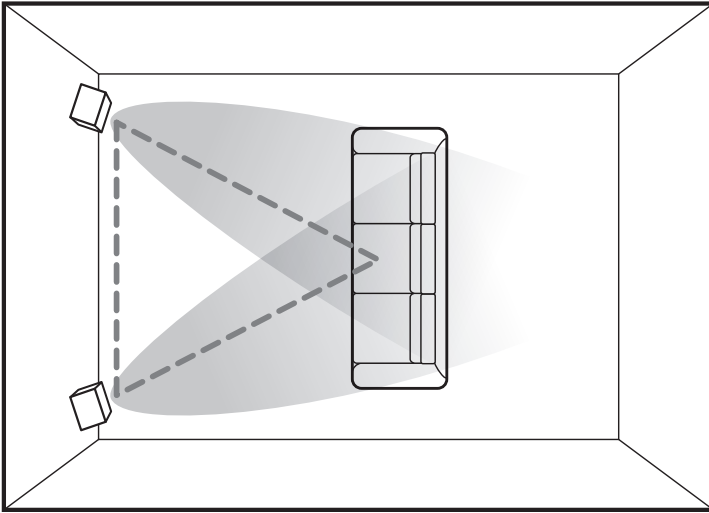

However, room anomalies may require that a speaker be toed further in or out. Toeing a speaker out (adjusting the angle of the speaker outward including straight forward) will widen your soundstage. The opposite will occur when toeing a speaker in.

- Proximity to walls and corners will increase low frequency output. When placed too close this additional low frequency output may sound unnatural or bloated. Whenever possible place your speakers no closer than two feet to the nearest wall.

Setting the Outlaw Loudspeaker's Controls

Boundary Compensation Switch

Depending on the proximity of your Outlaw Loudspeaker(s) to a wall or corner, you may find that certain upper bass frequencies sound boomy, or excessively hot. At these critical frequencies, this added energy manifests itself as “chestiness,” particularly in male voices. To compensate for these compromised, but often-necessary speaker placements, the Outlaw Bookshelf Loudspeakers provide a custom Boundary Compensation Circuit.

While other manufacturers have recognized the importance of boundary compensation circuitry, they often fall short in their implementation, opting for a single “averaged” adjustment for all non-ideal speaker placements.

After carefully calculating the effects of wall proximity and corner loading on the Outlaw Loudspeakers, we have integrated a no-compromise Boundary Compensation Circuit that includes different settings for each of the major speaker placement locations.

These settings are:

- **Open air placement**
The speaker is more than 24 inches away from all walls.
- **Single wall placement**
The speaker is within 24 inches of a single wall.
- **Corner placement**
The speaker is located within 24 inches of two walls.

The available settings allow you to tailor the behavior of your Outlaw Loudspeakers for optimal performance under most listening room conditions. Using the following guidelines, adjust each speaker according to its individual environment. Keep in mind that this setting can and should vary by speaker when necessary.

When the Outlaw Loudspeaker is no closer than 24 inches to any wall, the Boundary switch should be set to “0”. If the Outlaw Loudspeaker is within 24 inches of a single wall, set the Boundary switch to “-2dB”. If the Outlaw Loudspeaker is corner loaded (within 24 inches of two different walls), use the “-4dB” boundary switch position.

High Frequency Switch

Each room imparts its own sonic signature to the signal that arrives at the listening position. In rooms with minimal wall treatments, significant glass (i.e. a large number of windows), hardwood or tile floors, the resulting sound may have an overemphasized high frequency response. This is typically characterized as a slight edginess that may present itself in the form of listening fatigue. In these listening environments we recommend using the “-2dB” position on the Outlaw Loudspeaker's High Frequency switch.

In overly dampened rooms with wall-to-wall carpets, extensive absorptive wall coverings, acoustic panels, etc., you may find the high frequency response lacking. This could be observed as a dull or less detailed performance. In these listening environments, we recommend selecting the “+2dB” position on the Outlaw Loudspeaker's High Frequency switch.

Since most listening rooms are fairly well balanced, with a mix of dampening and reflective surfaces the “0dB” position will be optimal for the majority of users.

External System Adjustments

Crossovers for use with powered subwoofers

The Outlaw Bookshelf Loudspeakers have a low frequency output that rivals many larger speakers. As a standalone speaker they will provide a tight and true-to-source reproduction of your audiophile grade recordings. But for those seeking that last octave of audibility you may wish to consider the addition of a powered subwoofer. Proper integration of sub and speaker begins with the careful selection of the crossover.

Some receivers and processors supply a series of crossover options to integrate your subwoofer. If you are using an Outlaw processor or receiver the optimal setting is 60Hz.

For other systems, you will need to consider the Outlaw Loudspeaker's +/-3dB down point of 54Hz. Based upon the prevailing use of symmetrical fourth order networks in receivers and processors, we suggest choosing the closest crossover point provided by your system that is equal to or greater than 60Hz.

Volume Level

When available, match the levels of all of your speakers, including the Outlaw Loudspeakers, as described in your receiver or processor owner's manual. We recommend using an SPL meter (such as Radio Shack part number 33-2050). When using the test tones, measure from the listening chair and set the meter to the 75 dB level. In order to accurately measure levels between channels use "C" weighting and the "slow" setting.

Surround Sound Considerations

A great speaker has many characteristics. Most importantly, it should have a linear response, with a large soundstage and precision imaging while at the same time be capable of reproducing considerable dynamics without sounding strained. If these design goals are accomplished, the speaker will be at home both in music only and full in-home theater systems.

With the above in mind, we offer the following advice when integrating your Outlaw Bookshelf Loudspeakers in a 5.1, 6.1 or 7.1 surround sound system.

- Tweeter height should remain as close to even as possible between your front left, center and right channel speakers. This helps maintain "timbre" which is the characteristic of a sound that separates itself from other sounds of the same volume level and pitch.

When a sound effect pans from one speaker to the next, you'll want your speakers' timbre to match as closely as possible. This will ensure that whatever instrument or sound effect you are hearing sounds the same, regardless of which speaker in your system it is emanating from.

- When using "direct radiating" speakers, like the Outlaw Loudspeaker's in the surround position, they should be placed just behind the listening position. While timbre remains very important, these speakers should be placed approximately 1-2 feet above the listener's ears to create a more diffused sound field.
- Surround back channels, more commonly used in newer DD-EX™ and DTS-ES™ soundtracks should be placed at the same height as the surround channels. If you are using a pair of speakers in the surround back position, they should each be placed approximately 30 degrees off of the center axis. If only a single surround back speaker is used, it should be placed on center axis.
- Today's blockbuster movie soundtracks take advantage of a dedicated subwoofer channel called the LFE (Low Frequency Effects). For this reason, we advocate the used of a powered subwoofer like our LFM series subs. Placement of the subwoofer will depend on room acoustics, so you'll want to consult with your subwoofer manufacturer for tips on getting the most from your sub. The Outlaw LFM series subwoofer manuals, which are available as a free download at www.outlawaudio.com, all share an excellent primer on subwoofer placement. We invite you to use that information to maximize your system's performance.

Caring for your Speakers

Exceptional efforts were taken during the design and manufacture of the Outlaw Bookshelf Loudspeakers so that they could provide you with a lifetime's worth of music and movie reproduction. Proper care along the way will ensure that they always look as great as they sound.

We recommend using a lint-free cloth to clean your speaker's cabinets. If necessary you may moisten that cloth with plain water. Special care should be taken to avoid getting water on the dome tweeter or woofer. Do not use any other solvents or chemicals as damage may occur.

Troubleshooting Guide

PROBLEM: No output from the speakers

- Check to ensure that your amplifier is powered on.
- Check to make sure your source (CD, DVD etc.) is actively outputting a signal.
- Check to ensure speaker wires are properly connected.

PROBLEM: Amplifier shuts down at power up or during high volume playback

- Check for a shorted speaker wire connection. This is observed as speaker wire that touches both the positive and negative (red and black) binding posts at the same time. This can occur at the amplifier or the speaker's binding posts.
- Check to make sure your speaker wires are connected properly.

PROBLEM: Woofer or tweeter sounds "distorted"

- Check bass and treble controls and return them to flat.
- Reduce volume of playback as amplifier may be "clipping"

Specifications

SENSITIVITY	87dB
RATED AMPLIFIER POWER	50-200watts
IMPEDANCE	8 Ohms
FREQUENCY RESPONSE	54Hz-22kHz ±3dB
DRIVERS Tweeter	1" Custom Silk Dome designed and manufactured with precision Scandanavian parts
Woofer	5-1/4" SEAS Driver with Diecast Magnesium basket, treated paper cone, low-loss rubber surround and 26mm CCAW voice coil.
LINEAR COIL TRAVEL	10mm p-p
BOUNDARY COMPENSATION SWITCH	0dB, -2dB, -4dB starting at 400Hz where it plateaus at 250Hz and remains flat to resonance
HIGH FREQUENCY SWITCH	+2dB, 0dB, -2dB starting at 4kHz and peaking at 20kHz
DIMENSIONS (HxDxW)	12-1/8" x 10-15/16" (w/ grille) x 7-1/4"
WEIGHT	16.5 lbs

The Outlaw Audio 30-Day Satisfaction Guarantee

This product is guaranteed to satisfy all your needs for a high performance bookshelf speaker system. If for any reason, you are not completely satisfied with it, please contact us at 866-OUTLAWA (688-5292) within 30 days of receipt of the unit and you will receive a return authorization.

Please save all of your packing material in that the speakers can get damaged in shipping without proper protection. We recommend that you keep

the packing (even after 30 days) so that if you ever move, the speakers will be adequately protected.

If you decide to return the speakers, your only cost will be the original shipping charge. When your loudspeakers arrive, we will inspect them to insure that they were shipped back to us in original condition. Upon satisfactory inspection, we will issue a full credit for your original purchase price.

Outlaw Audio Limited Warranty

This warranty protects the owner of the Outlaw Bookshelf Loudspeakers (the PRODUCT) for five (5) years from the date of purchase.

This warranty covers all defects in material and workmanship with the following specific exceptions. These are:

- Damage caused by improper installation or adjustment
- Damage caused by accident, unreasonable use or neglect
- Damage from failure to follow instructions contained in this Owner's Manual
- Damage from the performance of repairs by someone not authorized by Outlaw Audio
- Any unit on which the serial number has been defaced, modified, or removed
- Damage occurring during shipment
- Units which have been altered or modified in design, appearance or construction

This warranty covers only the actual defects within the PRODUCT itself. IT DOES NOT cover costs of installation in (or removal from) a fixed installation, or normal set-up, claims based on any misrepresentation by the seller, or performance variations resulting from installation related circumstances such as signal quality, AC power or incompatibilities with speakers and/or other system components.

During the warranty period, Outlaw Audio will, at its option, either repair the defect, or replace the defective product, or the defective parts, or components thereof at no charge to the owner for parts and labor covered by this warranty. If necessary repairs are not covered by this warranty, or if a unit is examined which is not in need of repair, you will be charged for the repairs and/or the examination. If non-warranted repairs are needed, we will notify you of the estimated cost and ask for your authorization to perform said repairs.

You must pay shipping charges incurred in getting your Product to the factory. We will pay the return shipping charges if the repairs are covered by the warranty. Please save the original shipping cartons as the unit MUST be returned in the original carton and packing.

(Replacement cartons are available at a modest charge.)

If your product needs service, please call Outlaw Audio Inc. at 866-OUTLAWA (688-5292).

You will need to present the original bill of sale to establish the date of purchase. In the event that the proof of purchase cannot be established with the original receipt, the warranty period shall be determined by the earliest date of manufacture shown on the unit, provided that the serial number label has not been altered in any manner, or by our records relating to that serial number.

In the event that you wish to return your Outlaw speakers back to us, for any reason, please call to arrange for a Return Authorization Number. This will insure that your problem is discussed with a service technician who will determine if there is a quick solution to your problem.

Outlaw Audio shall not be liable for, in any way responsible for, any incidental or consequential damages of any kind. Some states do not allow limitations on how long an implied warranty lasts and/or do not allow the exclusion of incidental or consequential damages, therefore, the limitations and exclusions stated herein may not apply to you. This warranty gives you specific legal rights; and you may also have other rights which vary from state to state.

THERE ARE NO WARRANTIES GIVEN BY OUTLAW AUDIO WHICH EXTEND BEYOND THE DESCRIPTION GIVEN HEREIN. ANY IMPLIED WARRANTIES OF FITNESS FOR PURPOSE SOLD, MERCHANTABILITY, DESCRIPTION, QUALITY OR ANY OTHER MATTERS ARE LIMITED TO THE TERMS OF THE EXPRESSED LIMITED WARRANTY STATED HEREIN.

Products are sold on the basis of specifications applicable at the time of sales. Outlaw Audio shall have no obligation to modify products once they have been sold.

This warranty is applicable only in the United States.

For applicability in other countries, please call Outlaw Audio.

